

28ASY

EQUIPTO[®]

TEARDOWN BENCH
ASSEMBLY INSTRUCTIONS

READ INSTRUCTIONS BEFORE ASSEMBLING

Toll-free Tel: 800-323-0801 Toll-free Fax: 888-859-2121
www.equipto.com

©EQUIPTO 2003

TEAR DOWN BENCH

Step

1

BACK STRINGER ASSEMBLY

BENCH LEGS

NO.	DEPTH	HEIGHT
#9921	28 1/2"	29"
#9922	28 1/2"	31 1/4"
#9923	28 1/2"	34"

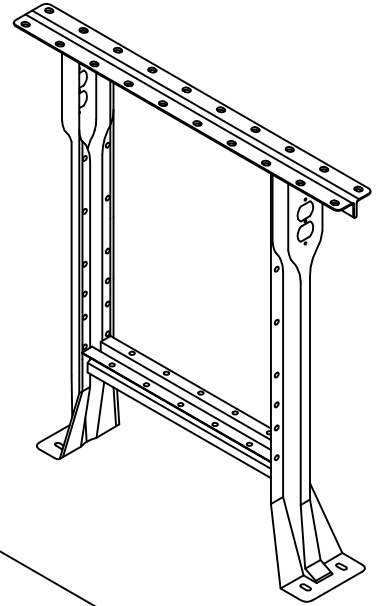

NOTE

DO NOT TIGHTEN THE BOLTS UNTIL THE WORKBENCH IS COMPLETELY ASSEMBLED.

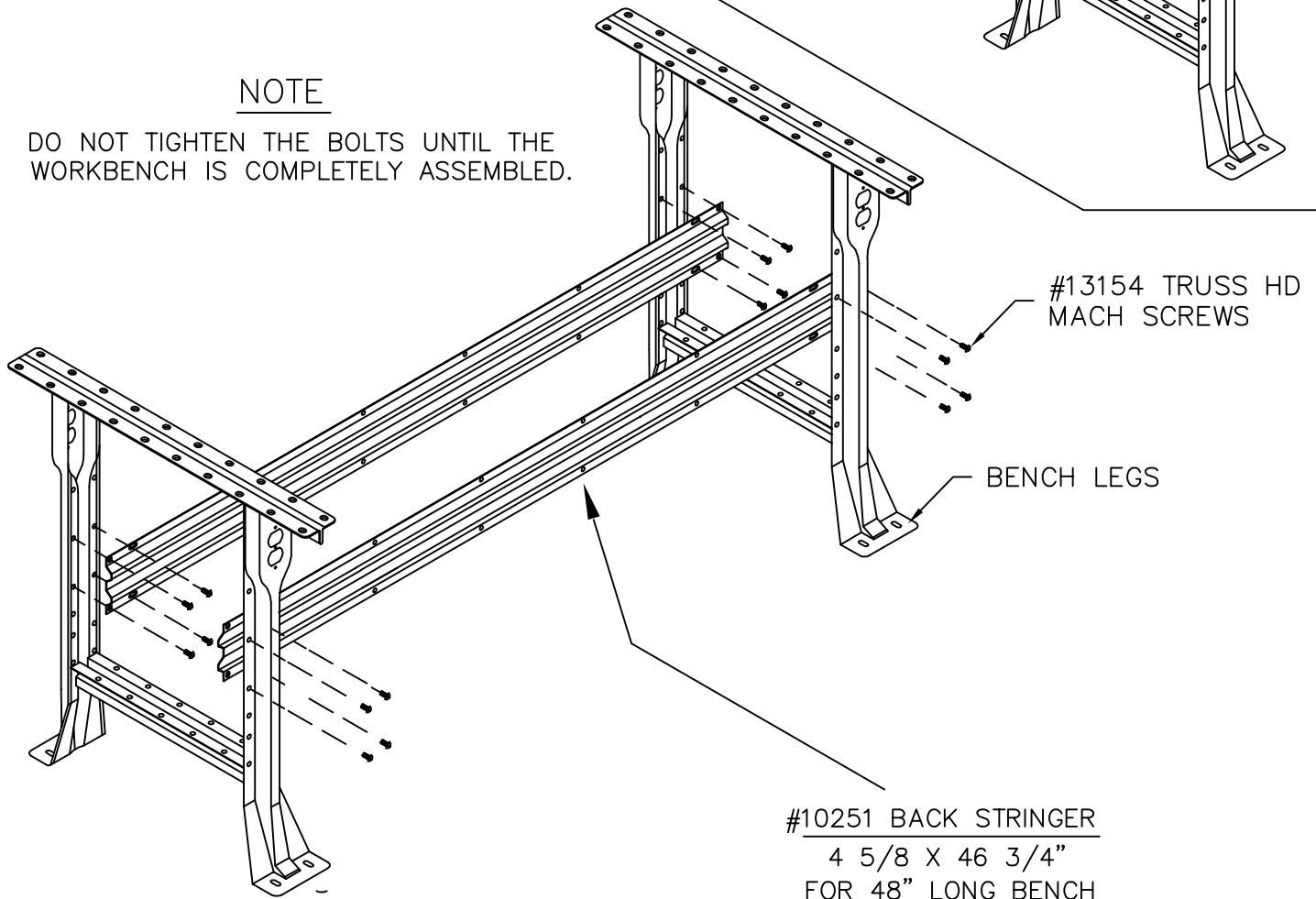

#13154 TRUSS HD MACH SCREW

5/16" X 3/4"

#13051 TWIN WHIZZ LOCKNUT

5/16" - 18

(8 PER STRINGER)

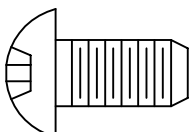

FULL SCALE

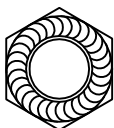

#10251 BACK STRINGER

4 5/8 X 46 3/4"

FOR 48" LONG BENCH

#10252 BACK STRINGER

4 5/8 X 58 3/4"

FOR 60" LONG BENCH

Step

2

TOP ASSEMBLY

NOTE – ALIGN HOLES IN BENCH TOP WITH HOLES IN TOP BRACES ON BENCH LEGS
SECURE TOP THIS STEP FOR BENCH LESS OPTIONS (E.G.. DRAWERS DRAINS PANS, CASTERS) FOR BENCH WITH WITH OPTIONS PROCEED TO PG. 3.

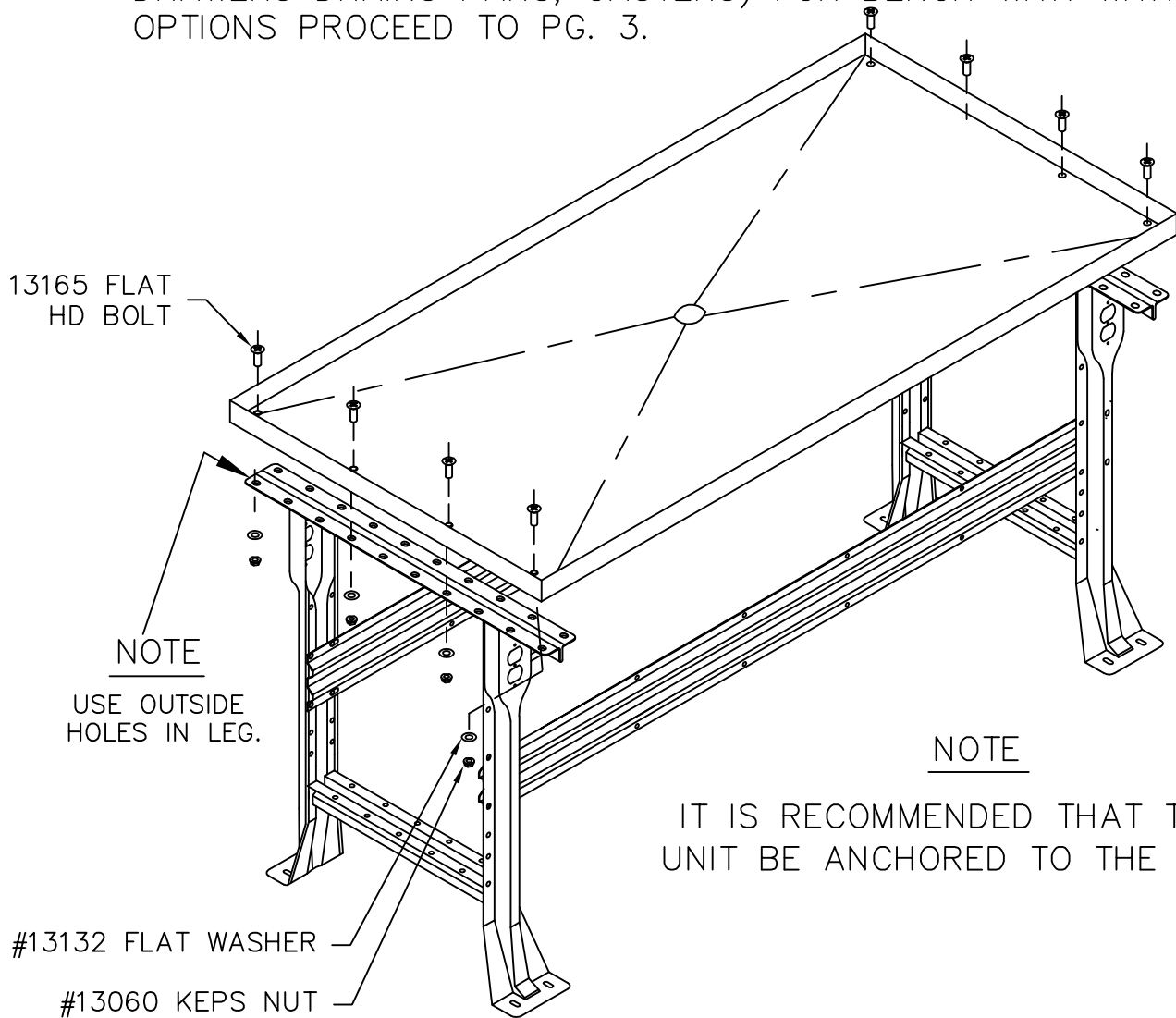

#13165 FLAT HEAD BOLT 1/4" x 1"
#13060 KEPS NUT 1/4"
(8 PER TOP)

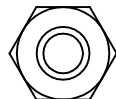

FULL SCALE

#13132 FLAT WASHER 1/4"
(8 PER TOP)

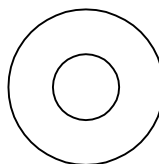

Optional

1a

BOTTOM SHELF ASSEMBLY

NOTE

ALL BENCHES DO NOT REQUIRE
A BOTTOM SHELF.

NOTE

DO NOT TIGHTEN THE BOLTS UNTIL THE
WORKBENCH IS COMPLETELY ASSEMBLED.

WHEN USING BOTTOM SHELF, THE STRINGERS
SHOULD BOTH BE PLACED ON BACK OF BENCH
FOR INCREASED STABILITY

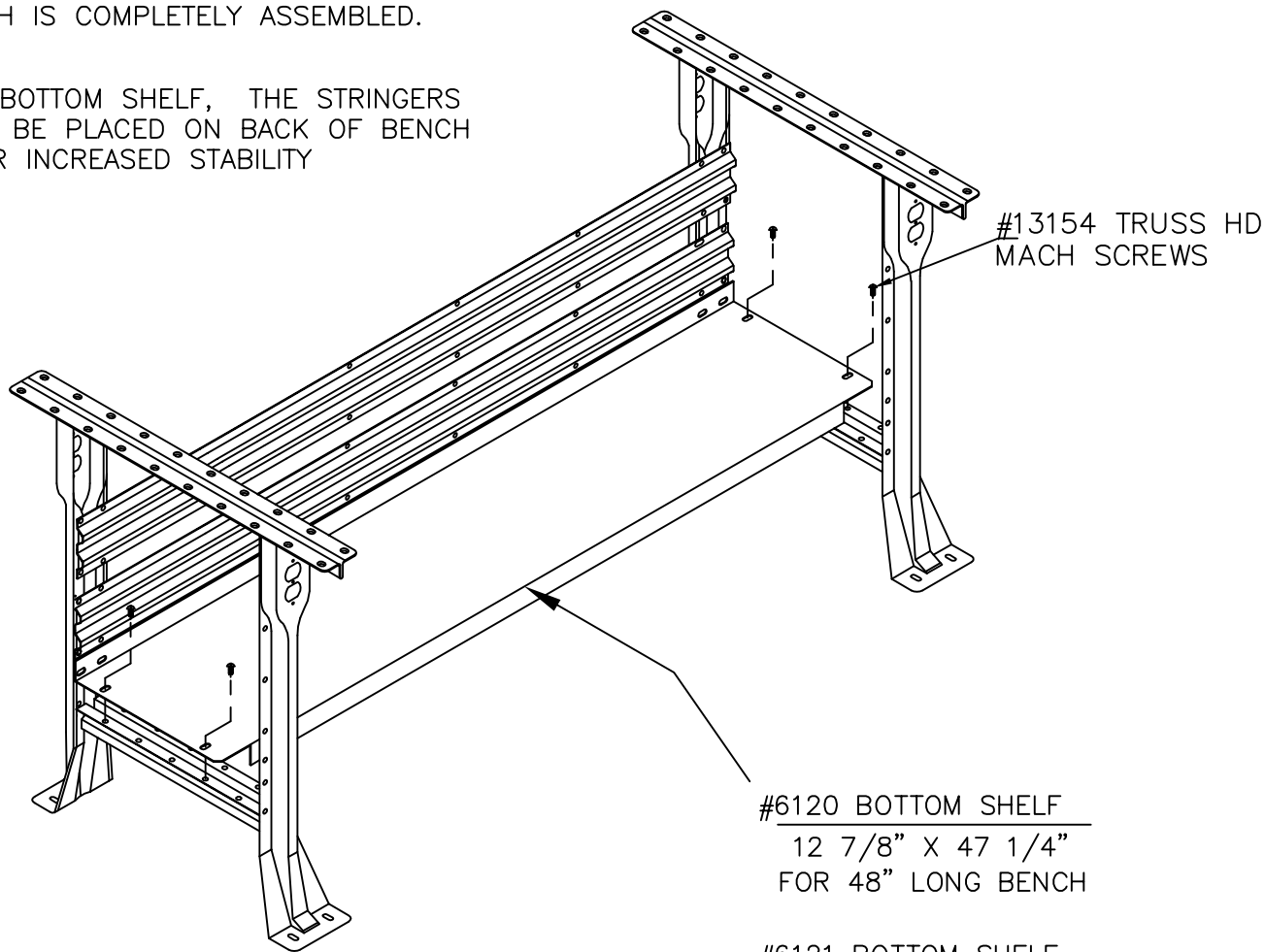

#6120 BOTTOM SHELF
12 7/8" X 47 1/4"
FOR 48" LONG BENCH

#6121 BOTTOM SHELF
12 7/8" X 59 1/4"
FOR 60" LONG BENCH

#13154 TRUSS HD MACH SCREW
5/16" X 3/4"

#13051 TWIN WHIZZ LOCKNUT
5/16" - 18

(4 PER BOTTOM SHELF)

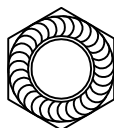
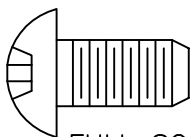

FULL SCALE

Optional

2a

DRAWER MOUNTING CHANNELS

- a) REMOVE DRAWER FROM FRAME
- b) ATTACH CHANNEL TO FRAME USING FORWARD HOLE ON FRAME AND SECOND HOLE ON CHANNEL
- c) ATTACH CHANNEL TO DRAWER FRAME IN REAR USING REAR HOLE IN FRAME AND THIRD HOLE IN CHANNEL

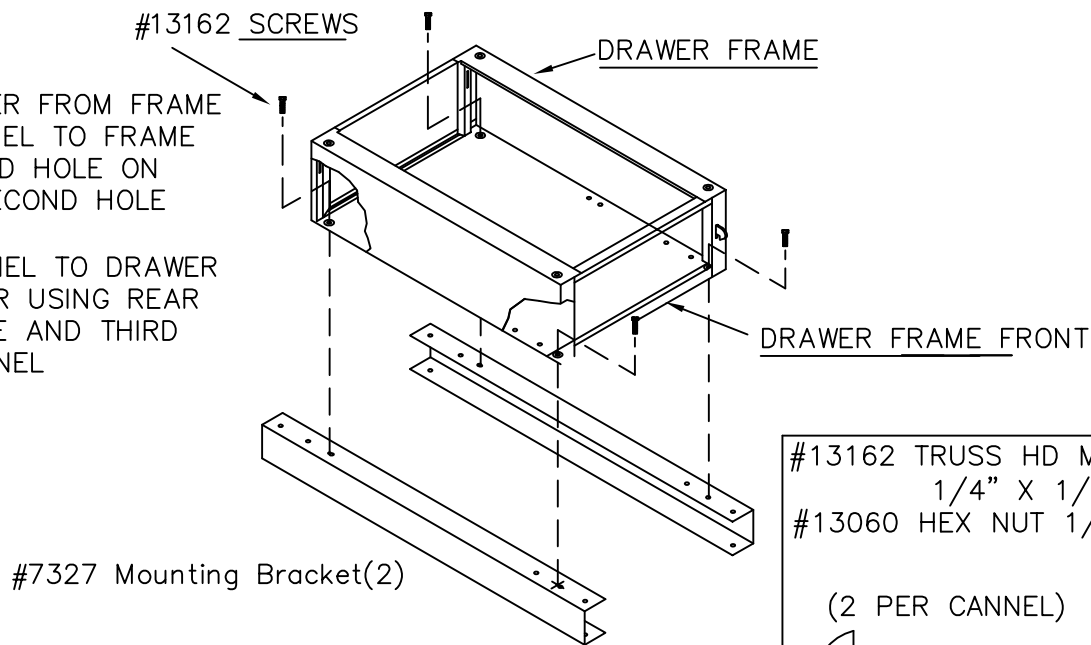

#13162 TRUSS HD MACH SCREW
1/4" X 1/2"
#13060 HEX NUT 1/4"
(2 PER CANNEL)

FULL SCALE

FRONT AND REAR BENCH CHANNELS

INSERT THE DRAWER MOUNTING ASSEMBLY INTO THE FRONT AND REAR CHANNELS. THE DRAWER CAN BE PLACED ON EITHER END OF THE BENCH. USE THE TWO HOLES CLOSEST TO THE DESIRED END.

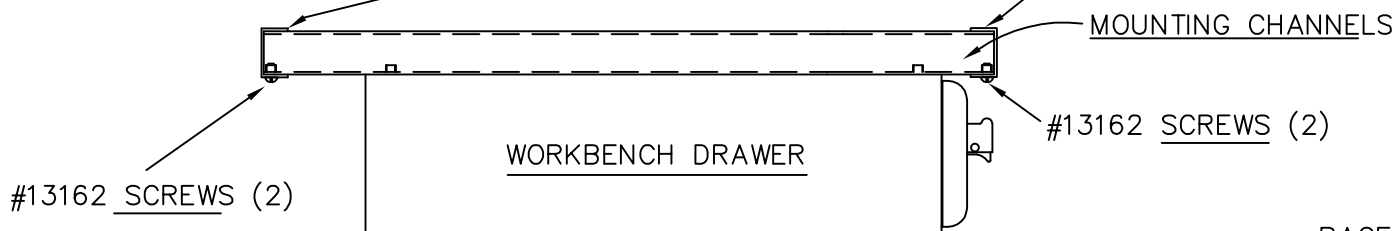
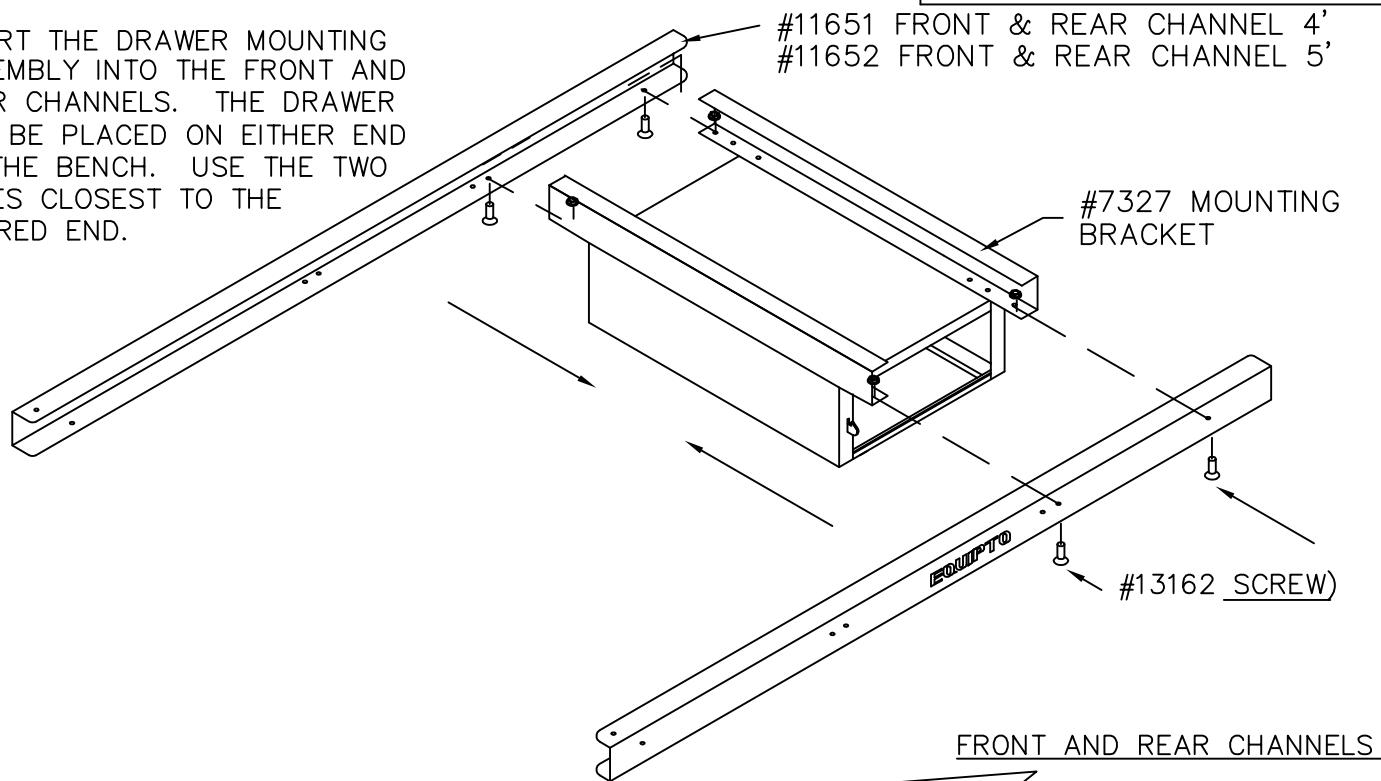

Optional

2b

DRAIN PAN GUIDES

BOLT DRAIN PAN GUIDES TO UNDERSIDE
OF MOUNTING ASSEMBLY USING #13162
AND #13060 KEPS NUTS

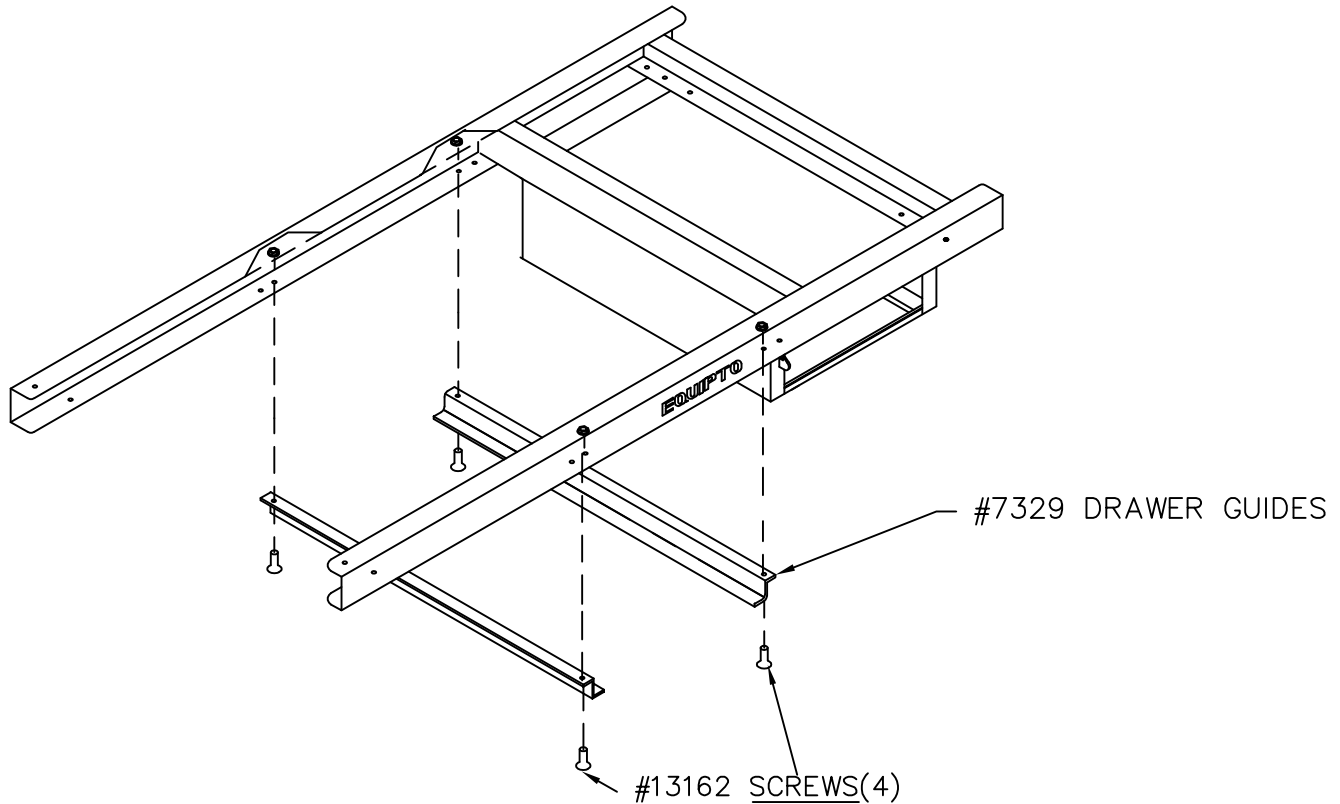

3a

SUB ASSEMBLY TO BENCH

(SEE NEXT PAGE)

- a) SLIDE OPEN END OF ASSEMBLY OVER BENCH LEG SO THAT TOP FLANGE OF FRONT AND REAR CHANNELS REST ON TOP OF BENCH LEG
- b) SLIDE DRAWER END OF ASSEMBLY OVER BENCH LEG SO THAT TOP FLANGE OF FRONT AND REAR CHANNELS REST ON TOP OF BENCH LEG
- c) CAREFULLY ALIGN HOLES ON CHANNELS WITH OUTER HOLES ON BENCH LEGS

Optional

3a

SUB ASSEMBLY TO BENCH (Cont'd)

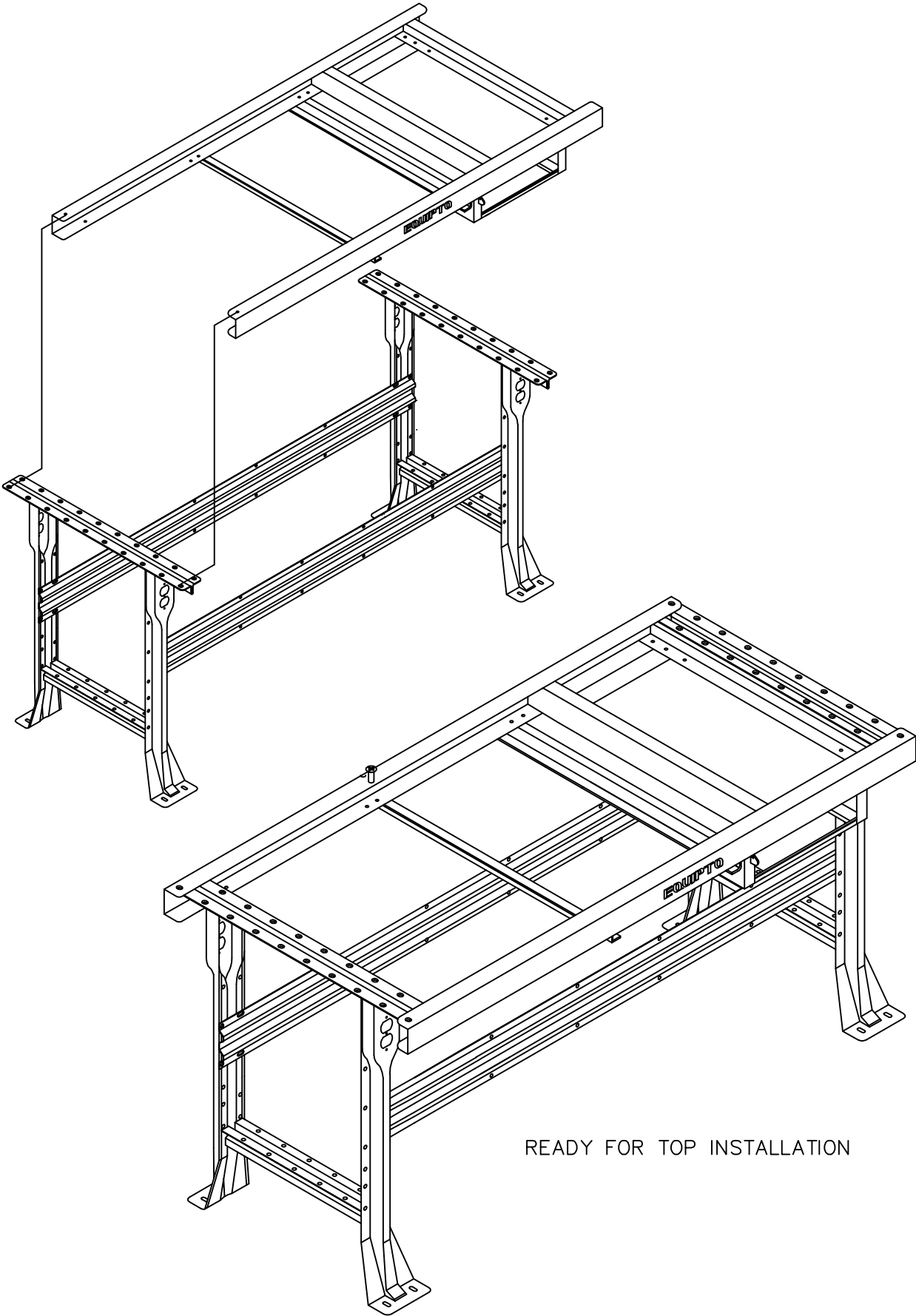

READY FOR TOP INSTALLATION

Optional

4a

TOP ASSEMBLY

FASTEN TOP TO FRAME
ALIGN HOLES IN DRAIN TOP WITH OUTER HOLES
ON TOP BRACES ON BENCH LEGS

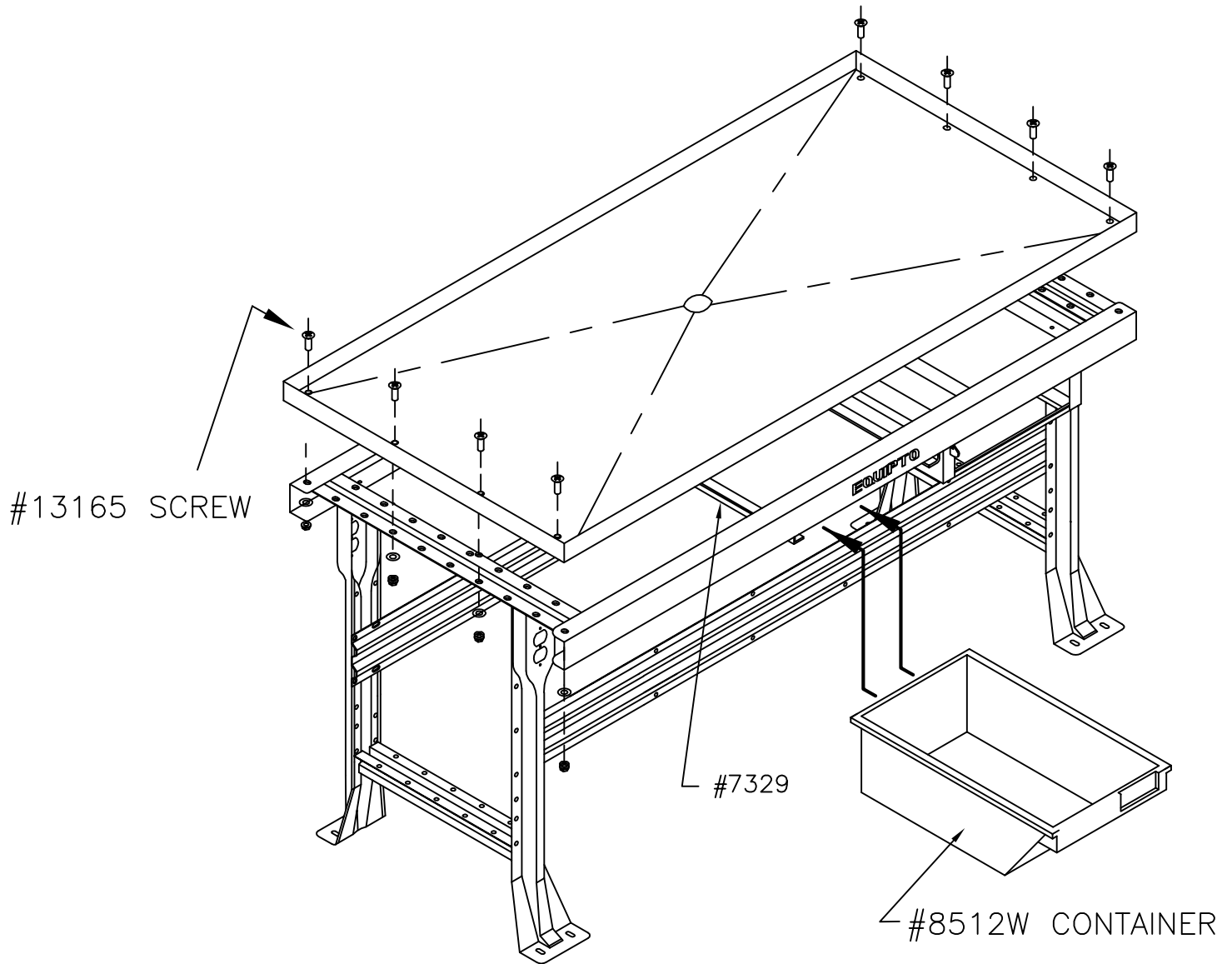

INSERT #8512W INTO DRAIN PAN GUIDES
NOTE - DRAIN PAN MUST BE PLACED UNDER
HOLE IN DRAIN TOP

#13165 FLAT HEAD BOLT 1/4" x 1"

#13060 KEPS NUT 1/4"

(8 PER TOP)

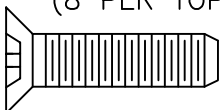

FULL SCALE

#13132 FLAT WASHER 1/4"

(8 PER TOP)

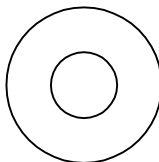

Optional

5a

DRAWER INSTALLATION

a. STOP CLIPS INSTALLATION

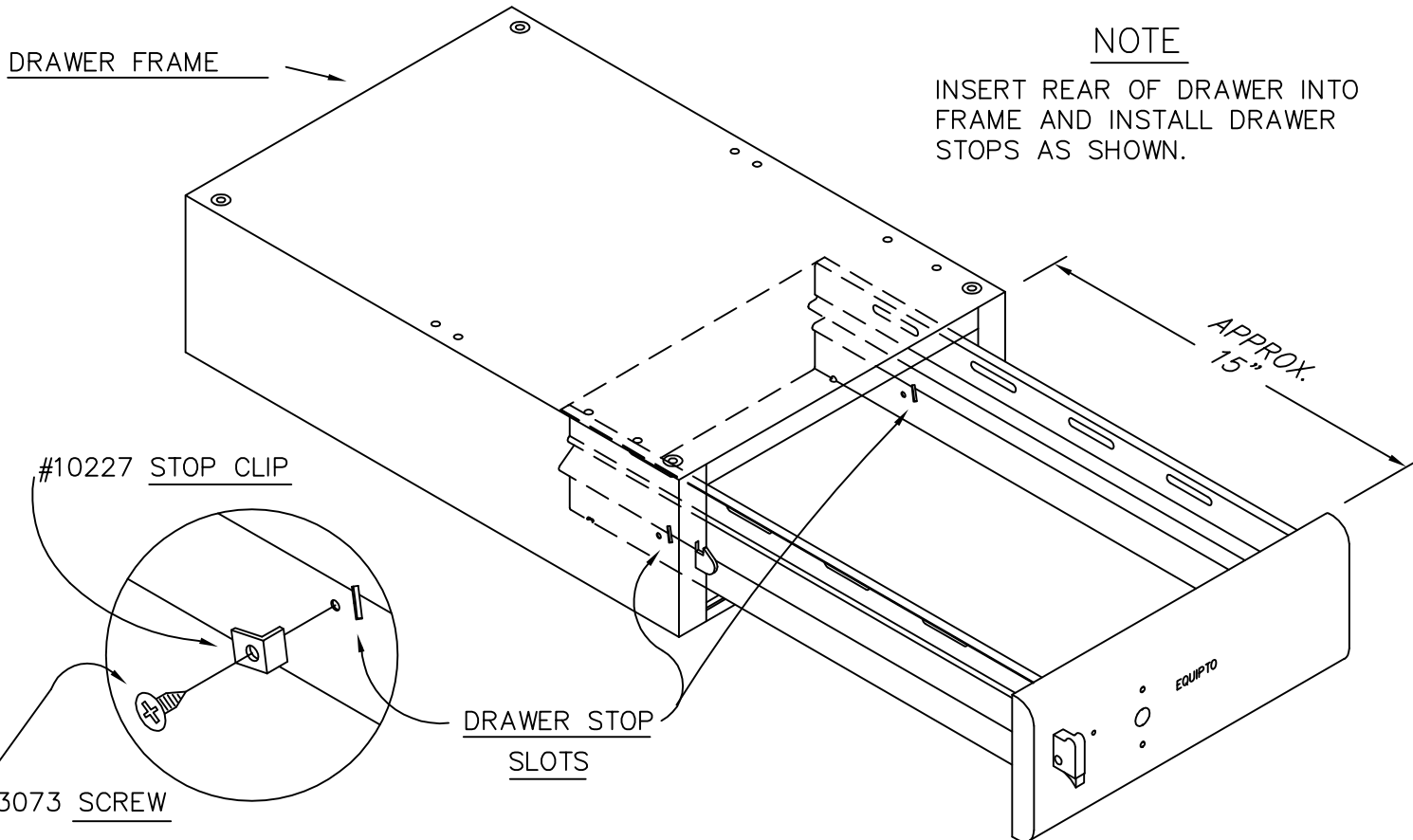

b. LINER INSTALLATION

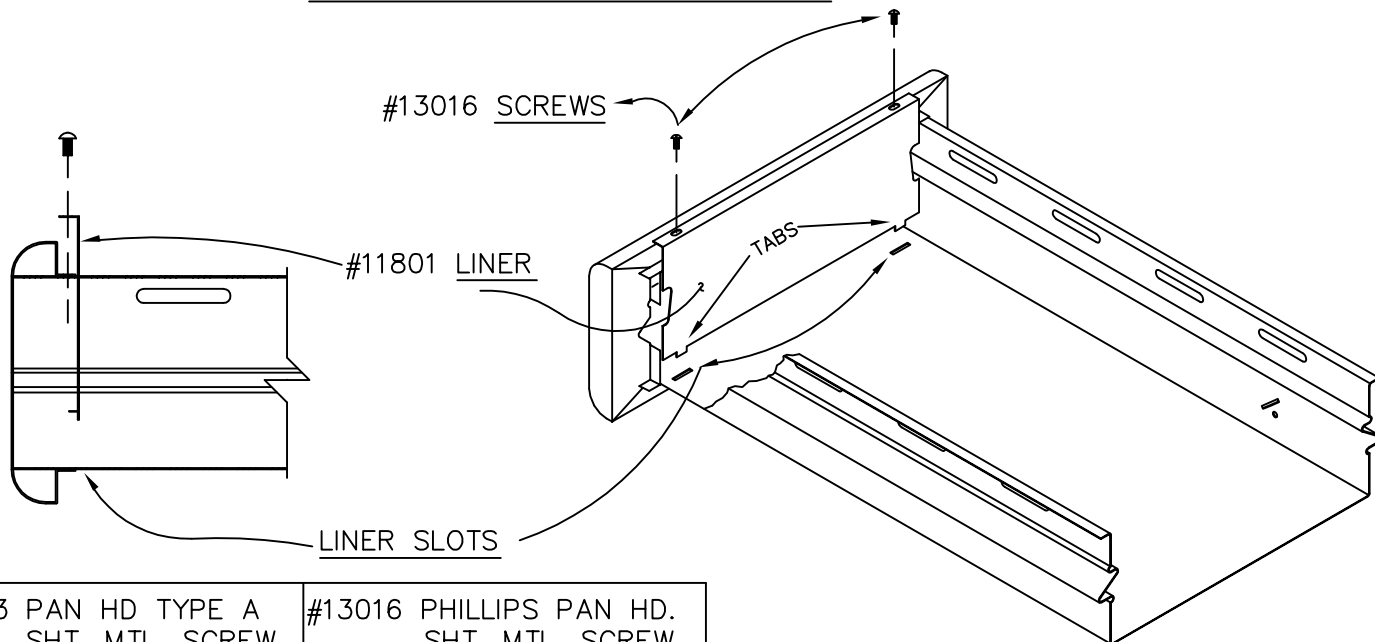

#13073 PAN HD TYPE A
SHT. MTL. SCREW
1/4" X 3/8"
(2 PER DRAWER)

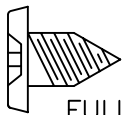

FULL SCALE

#13016 PHILLIPS PAN HD.
SHT. MTL. SCREW
#8 X 3/8"
(2 PER DRAWER)

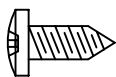

FULL SCALE

Optional

Step

6

MOBILE CASTER KIT

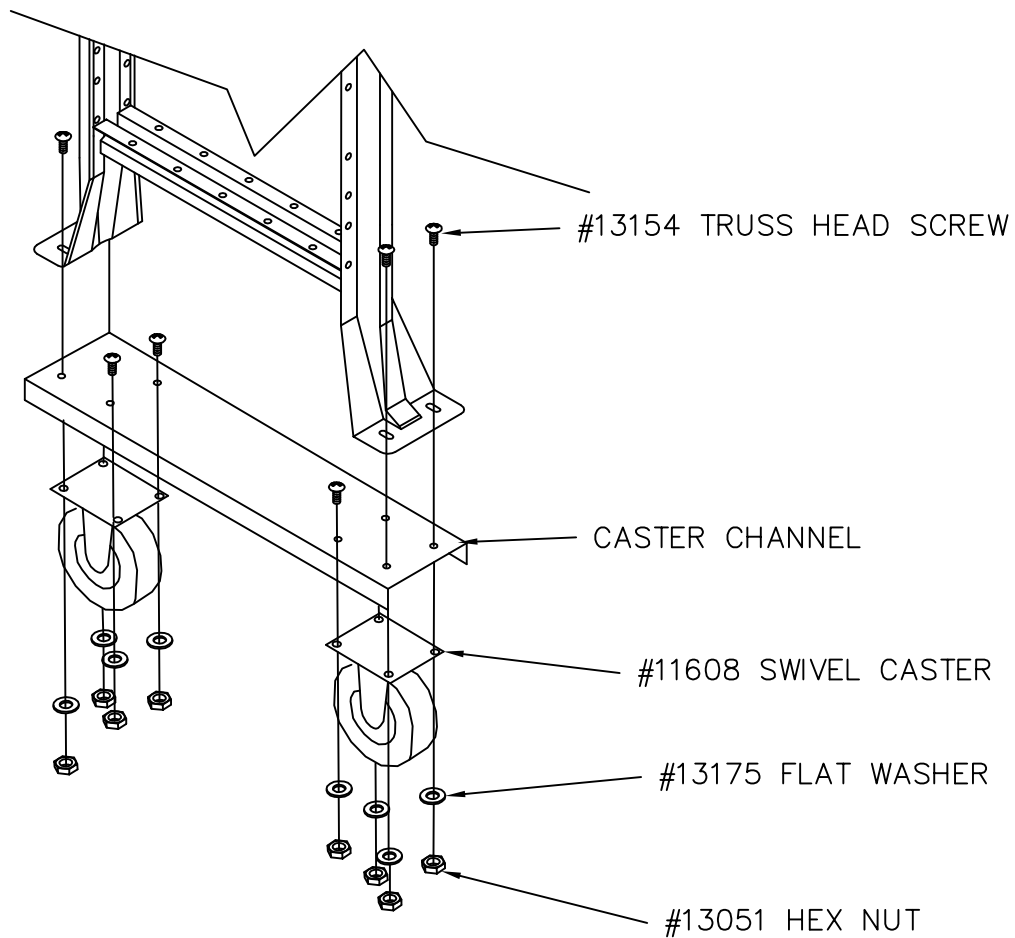

#13154 TRUSS HEAD SCREW 5/16"-18 x 3/4"

#13057 HEX NUT 5/16"

#13175 FLAT WASHER 5/16"

(4 PER CASTER)

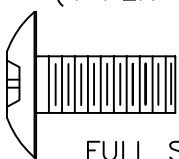

FULL SCALE

